

Field Day Filters For Same-Band CW/Phone Interference

Nelson Sollenberger
KA2C

Hamcation 2022 – Friday, Feb 11

Field Day Interference Issue

- Space antennas as much as possible
- Antenna isolation techniques
 - Cross polarization (vertical to dipole)
 - End to end dipoles
 - Use sidelobes/backlobes of Yagi beams,...
- Low TX noise and high dynamic range RX radios
- Bandpass filters for inter-band interference
- Same-band Ultra-Sharp filters
 - 1) RX only
 - 2) Low-Loss suitable for 100 watt TX

Ultra-Sharp RX (USRX) Filters

- Suitable to isolate CW/digital from phone signals on the same band
- Accept several dB of loss during RX
- Bypassed for TX
- Addresses RX overload/intermod from very strong nearby signals in frequency
- Does not address TX noise (phase noise – total noise) which requires filtering at the TX output at high power

40 Meters USRX Phone Filter Measured Response

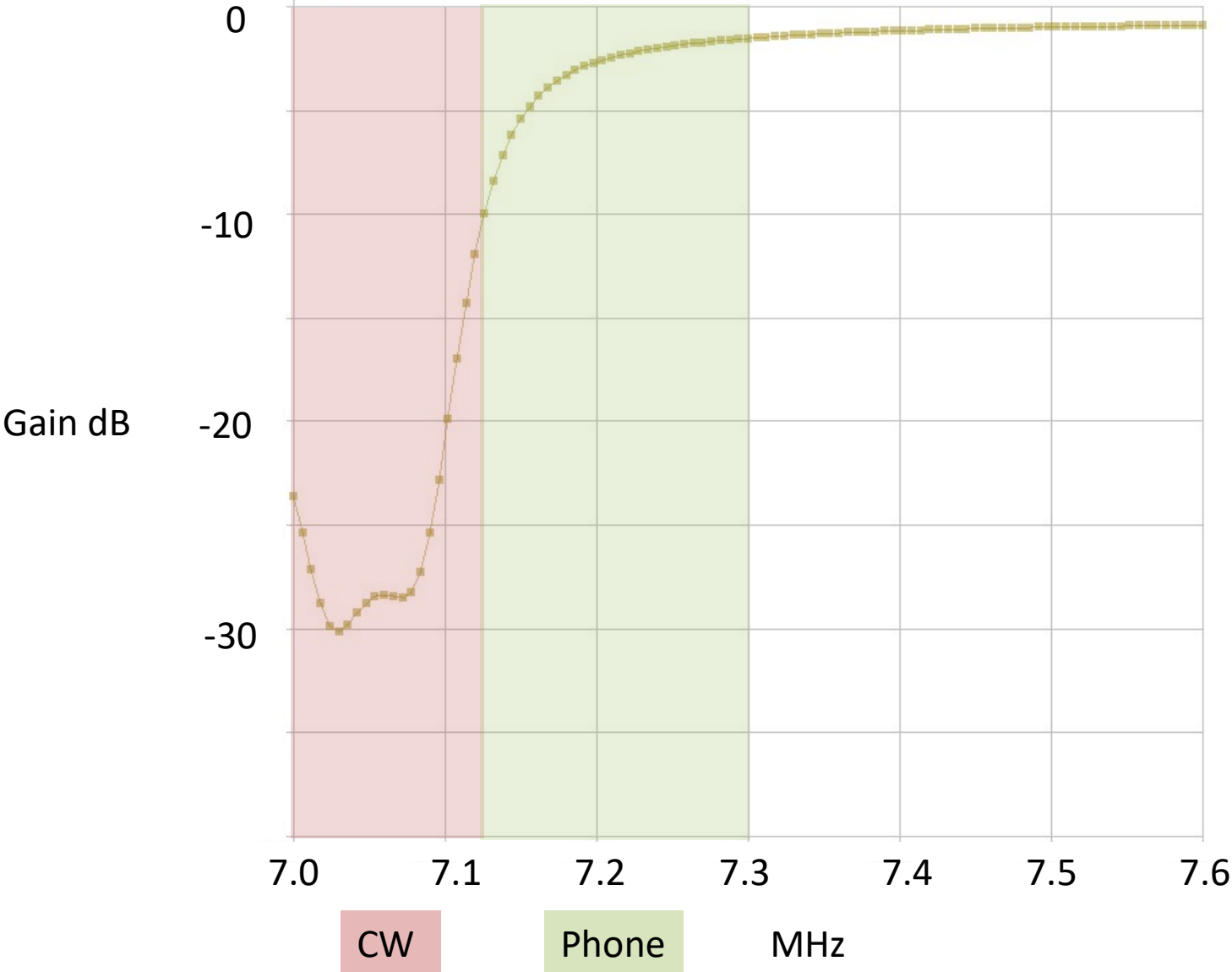

40 Meters USRX Phone Filter Wide Measured Response

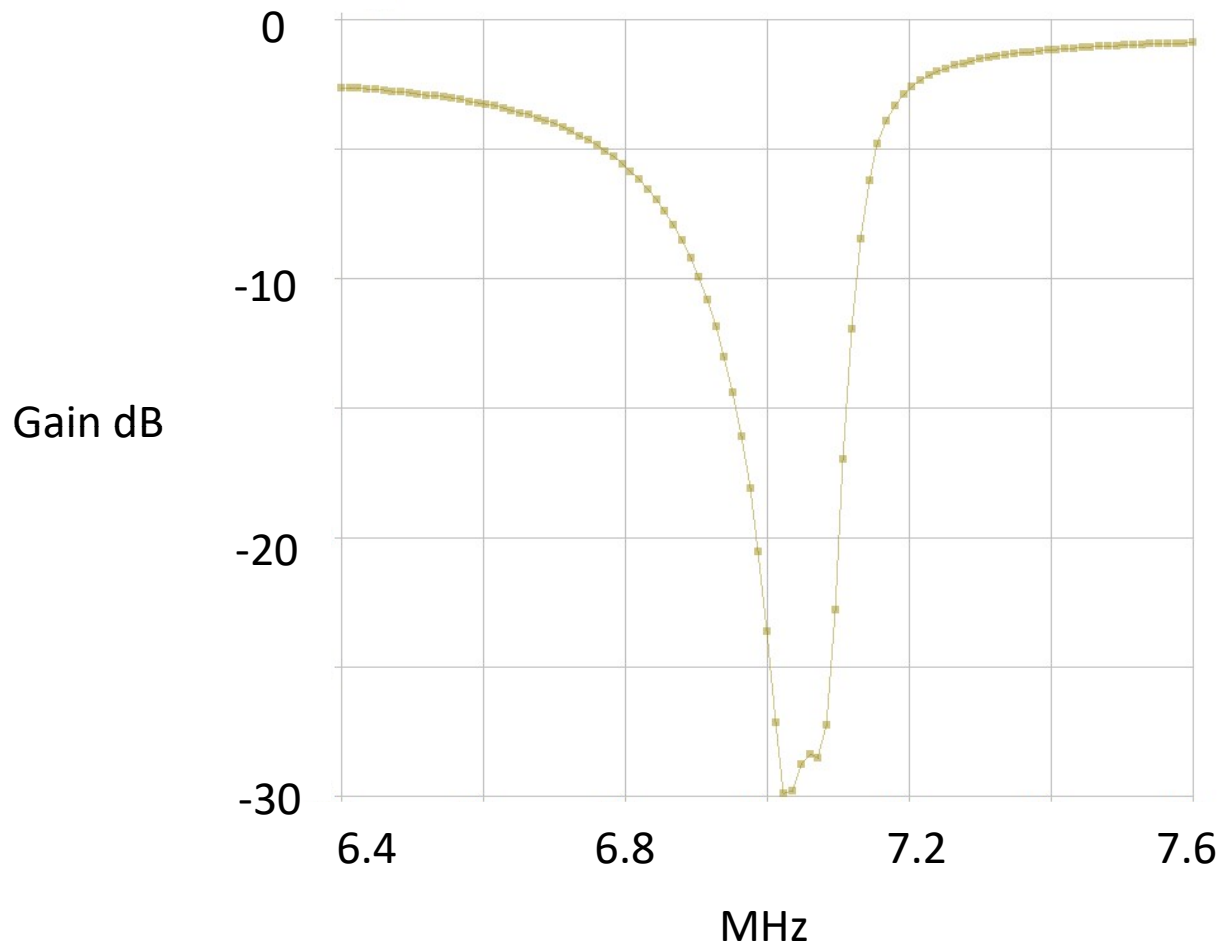

- Conventional bandpass filters should be used in series with USRX filters
- Bandpass bumps are on one side of the bandstop region

40 Meters Phone USRX Filter Schematic

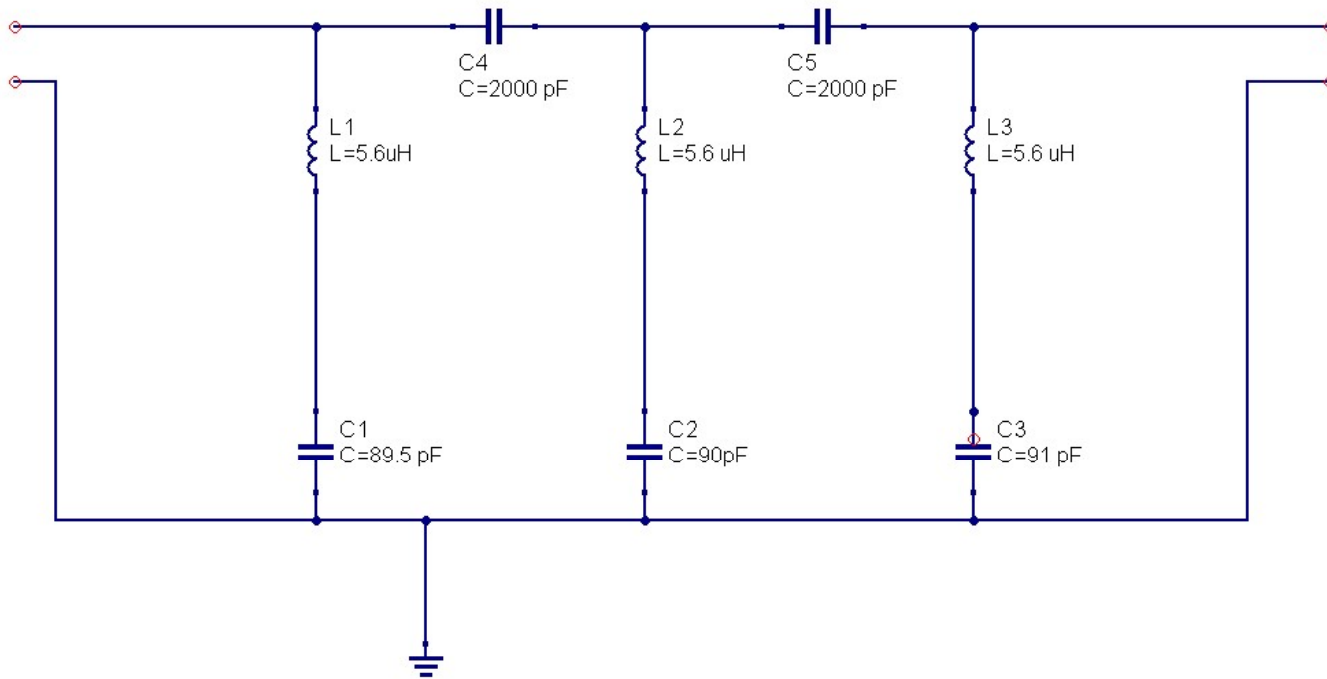

- L1C1, L2C2 and L3C3 form 3 notch filter resonances spread across the CW band
- L1C1C4L2C2, L2C2C5L3C3 and L1C1C4C5L3C3 form 3 bump bandpass filter resonances that are spread across the phone band
- 50 to 12.5 Ohm RF transformers are used at input/output to optimize matching (not shown in schematic)

40 Meters Phone USRX Filter Resonance Points

- L1C1, L2C2 and L3C3 provide 3 notch resonances spread across the CW band

 - L1C1 -> 7.109 MHz

 - L2C2 -> 7.089 MHz

 - L3C3 -> 7.050 MHz

- L1C1C4L2C2, L2C2C5L3C3 and L1C1C4C5L3C3 provide 3 bump bandpass resonances that are spread across the phone band

- inductors in series add

- Capacitors in series add admittance ($1/(1/C1 + 1/C2 + \dots)$)

 - L1C1C4L2C2 -> 11.2 uH & 43.89 pF -> 7.178 MHz

 - L2C2C3L3C3 -> 11.2 uH & 44.25 pF -> 7.149 MHz

 - L1C1C4C5L3C3 -> 11.2 uH & 43.17 pF ->7.238 MHz

- Bandpass bump frequencies

 - Above the notch frequencies with capacitive coupling

 - Below the notch frequencies with inductive coupling

Detailed Simulation Model With Parasitic R L & C Elements

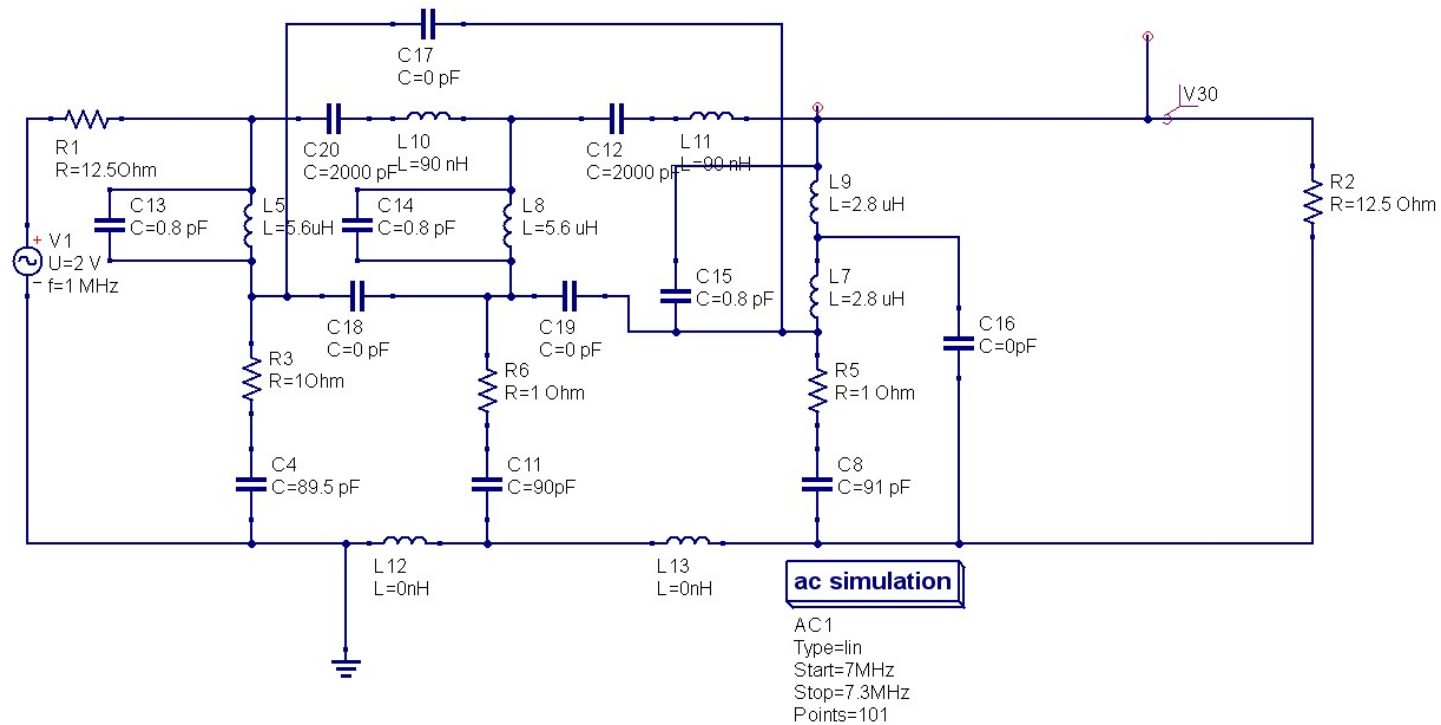

Important Parasitics:

- Equivalent RF resistance of inductors that dominate Q factors
- Capacitance across inductors
- Inductance in series with inter-stage coupling C's

USRX 40 Meters Phone Filter

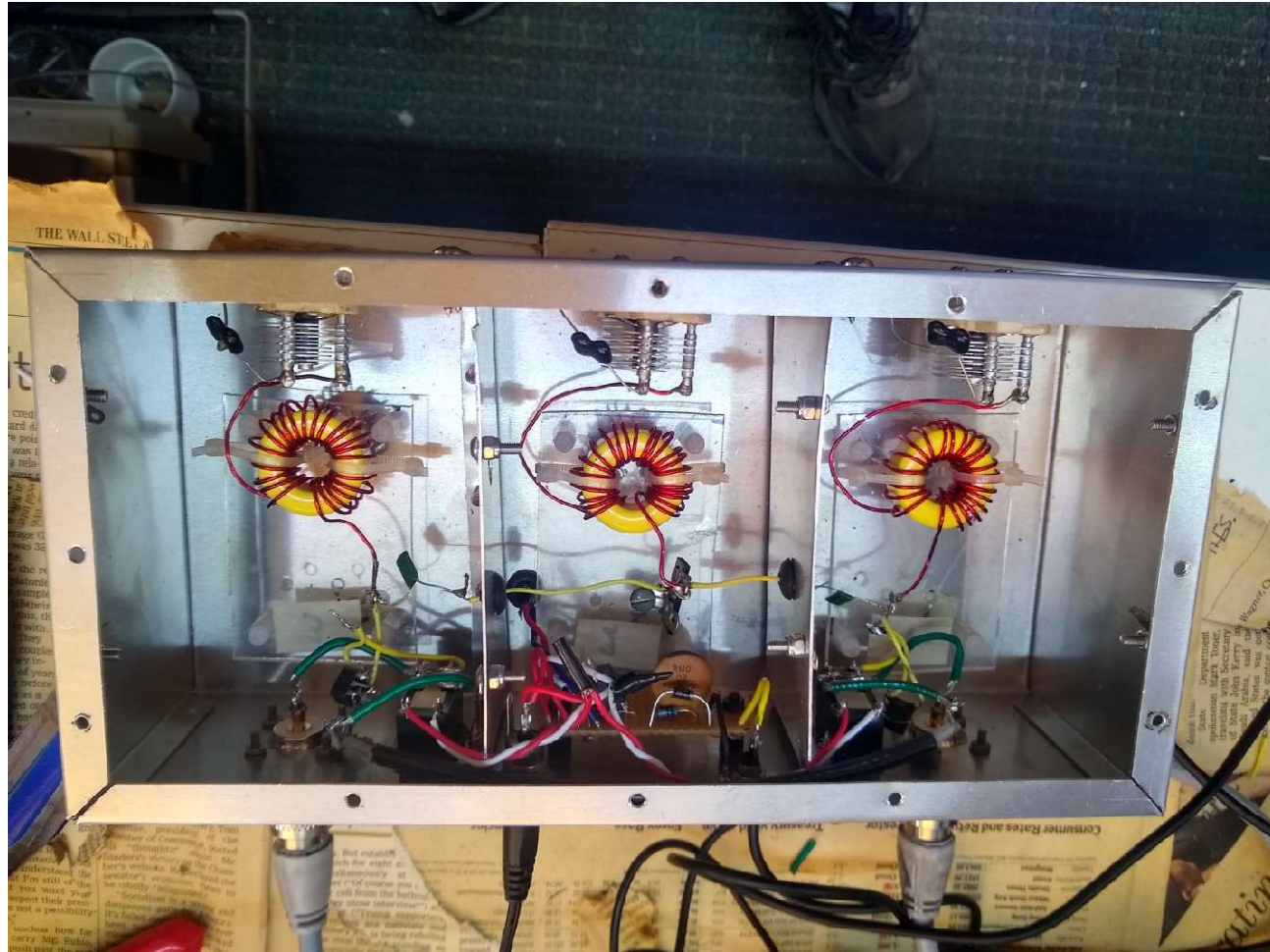

USRX TX/RX Relays and Control

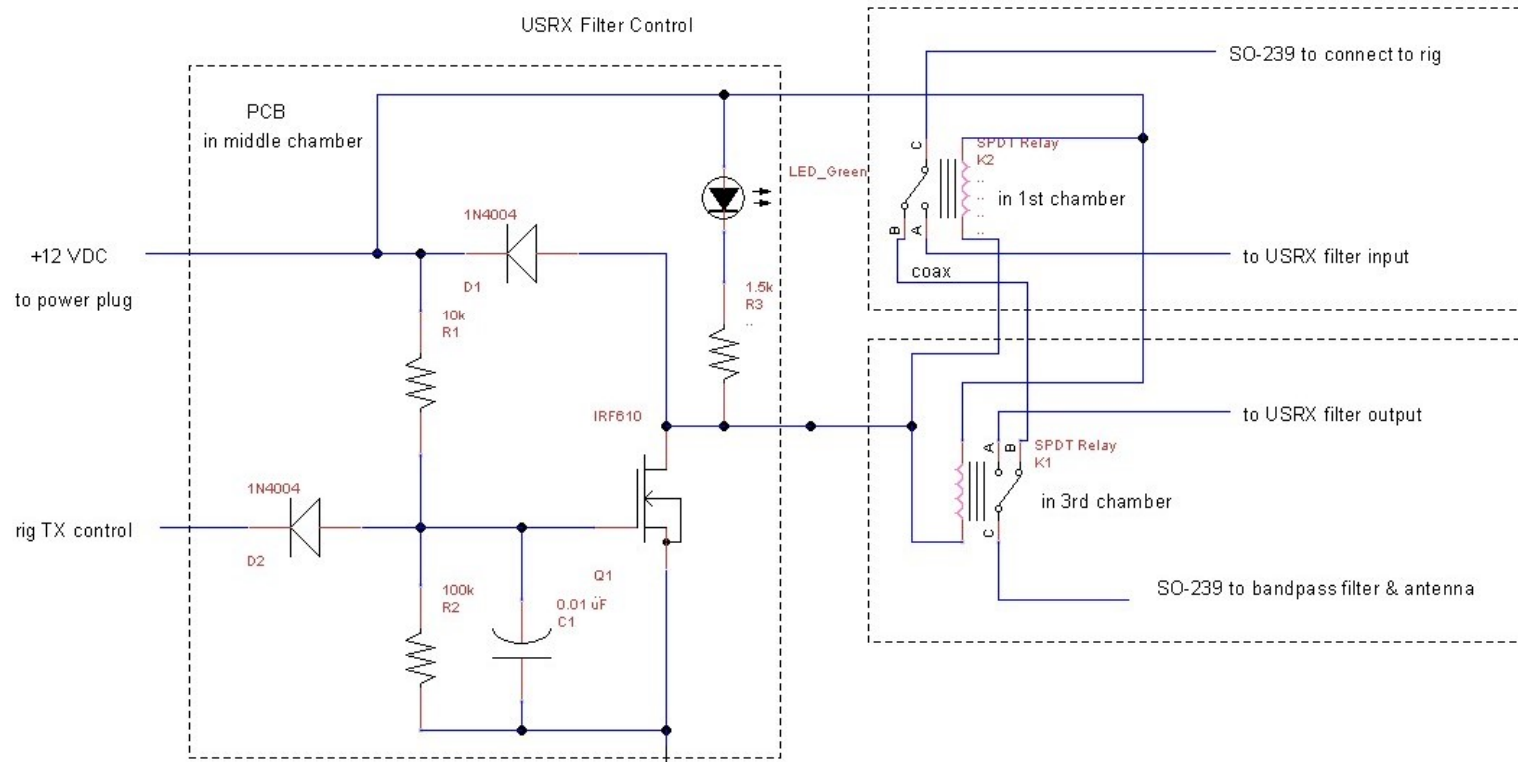

- Relays are in bypass TX mode with no power (safe from loss of power)
- LED indicates power and RX mode
- A toggle switch (not shown) from control to ground provides manual operation

Key Components for USRX Filters

- 3"x5"x10" aluminum chassis
- T106-6 toroid cores
- Johnson slot tunable air capacitors
- Coilcraft RF 4:1 WB4-6L transformers
- Potter and Brumfield RTD14012F relays
- IRF610 MOSFET
- Silver Mica fixed caps
- 12 VDC power plug

Key Tools

- QUCS or other analog/RF circuit simulator
 - Lumped element simulator
 - Frequency response, voltage & current modeling
- NanoVNA or other RF measurement test eqpt
 - Measured frequency response
 - Continuous sweeps facilitates rapid tuning
- Measured results of single filter stages and single components can provide models for accurate simulations of complex filters

Ultra-Sharp Low-Loss (USLL) Filters

- Suitable to isolate CW/digital from phone signals on the same band
- Only 0.5 to 1.0 dB of loss during RX/TX in passband
- Direct coupled at 50 Ohms input/output impedance
- Addresses RX overload/intermod from very strong nearby signals (50 to 100 KHz minimum separation) with 20 to 40 dB of suppression
- Addresses TX noise (phase noise – total noise) with 20 to 40 dB of suppression
- Requires very high-Q resonators (coils) and high voltage/current RF capability
- Physically large – 6"x6"x18"

40 Meters USLL CW Filter Measured Response

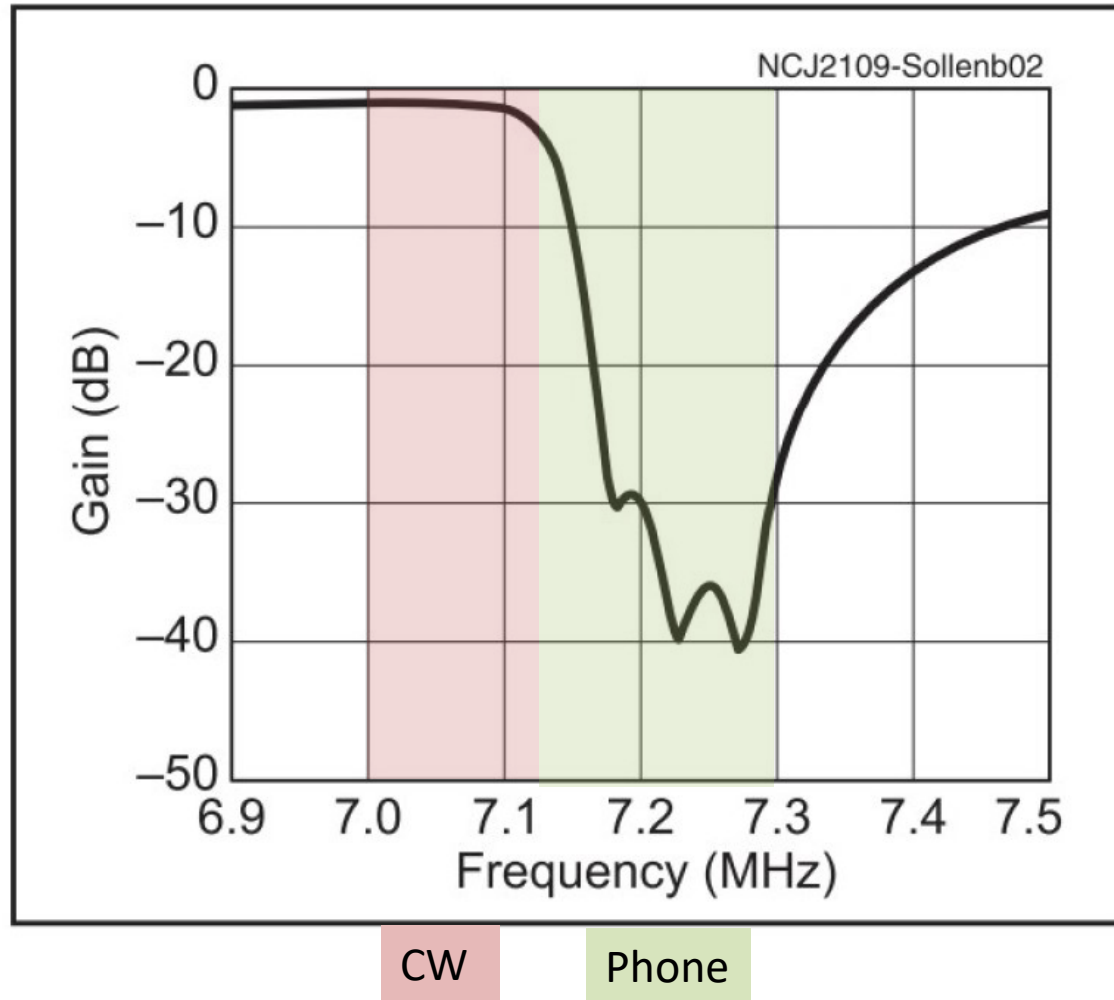

Reprinted with the permission of the ARRL. Copyright ARRL

40 Meters CW USLL Filter Schematic

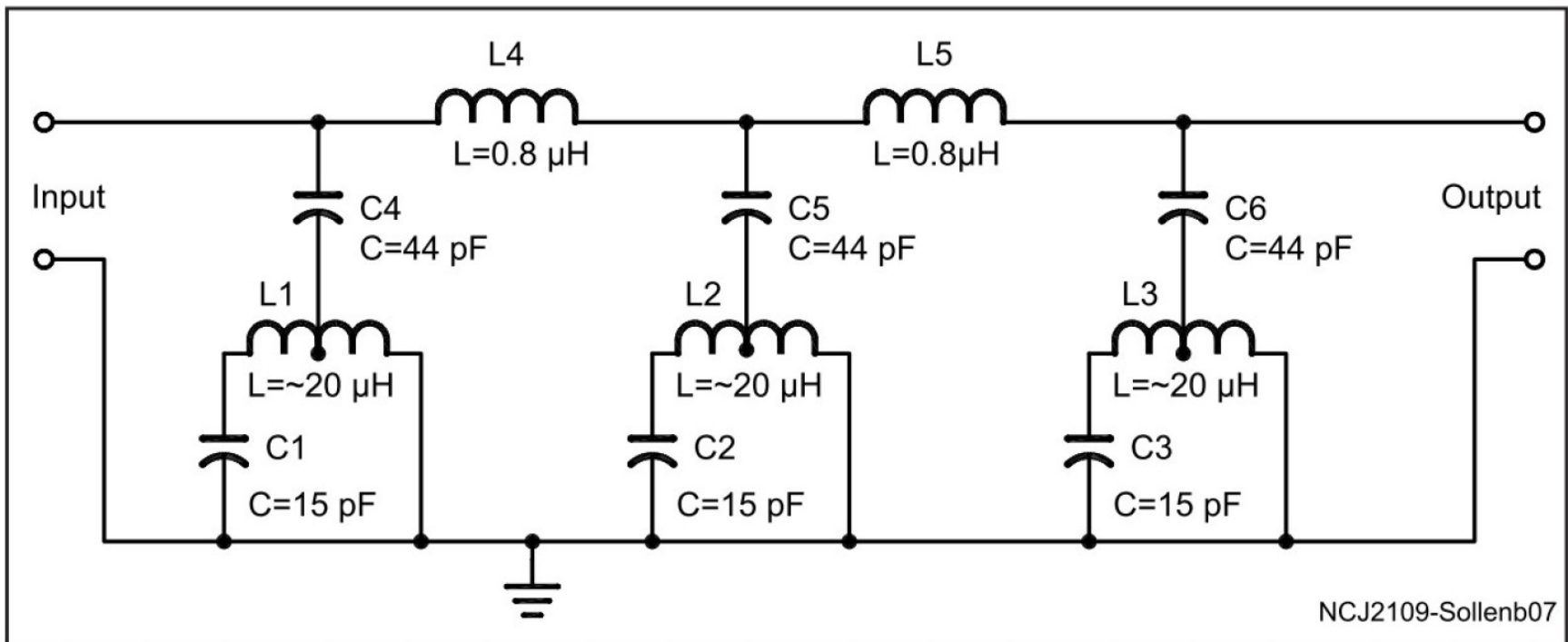

- Hybrid helical/lumped-circuit resonators in 6"x6"x6" aluminum chambers
- 3.5" diameter homebrew coils for very high Q
- Loose coupling to helical resonators to minimize losses by tapping coils with small capacitive coupling

Reprinted with the permission of the ARRL. Copyright ARRL

USLL 40 Meters CW Filter

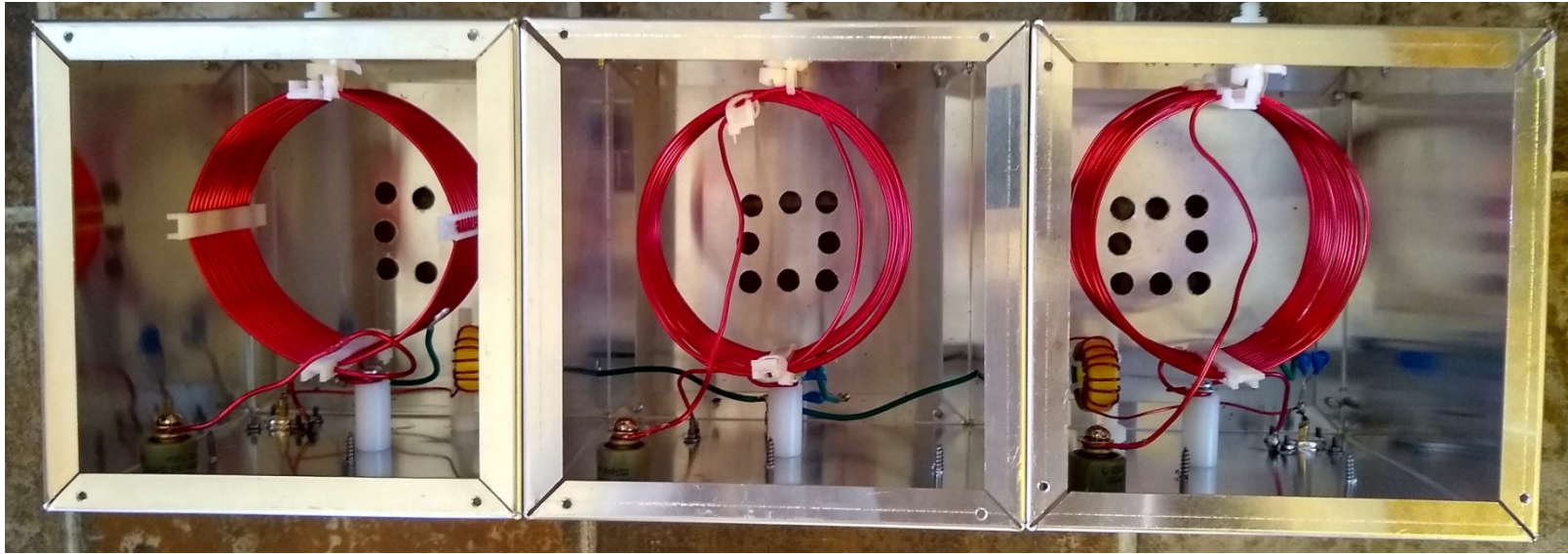

- Shown with top chamber covers removed
- 3.5" Coils mounted on 1 inch delrin insulators
- Small coupling inductors are toroids visible in 1st and 3rd chambers
- 15 pF doorknob RF capacitors mounted on lower chamber wall
- Signal coupled between chambers with green wire and the chambers provide a ground for the filter
- SO-239 connectors are in the 1st and 3rd chambers on the lower wall
- Place chamber seams on opposite side of SO-239 connectors to minimize RF current across the seam

Reprinted with the permission of the ARRL. Copyright ARRL

USLL 40 Meters CW Filter 3rd Chamber

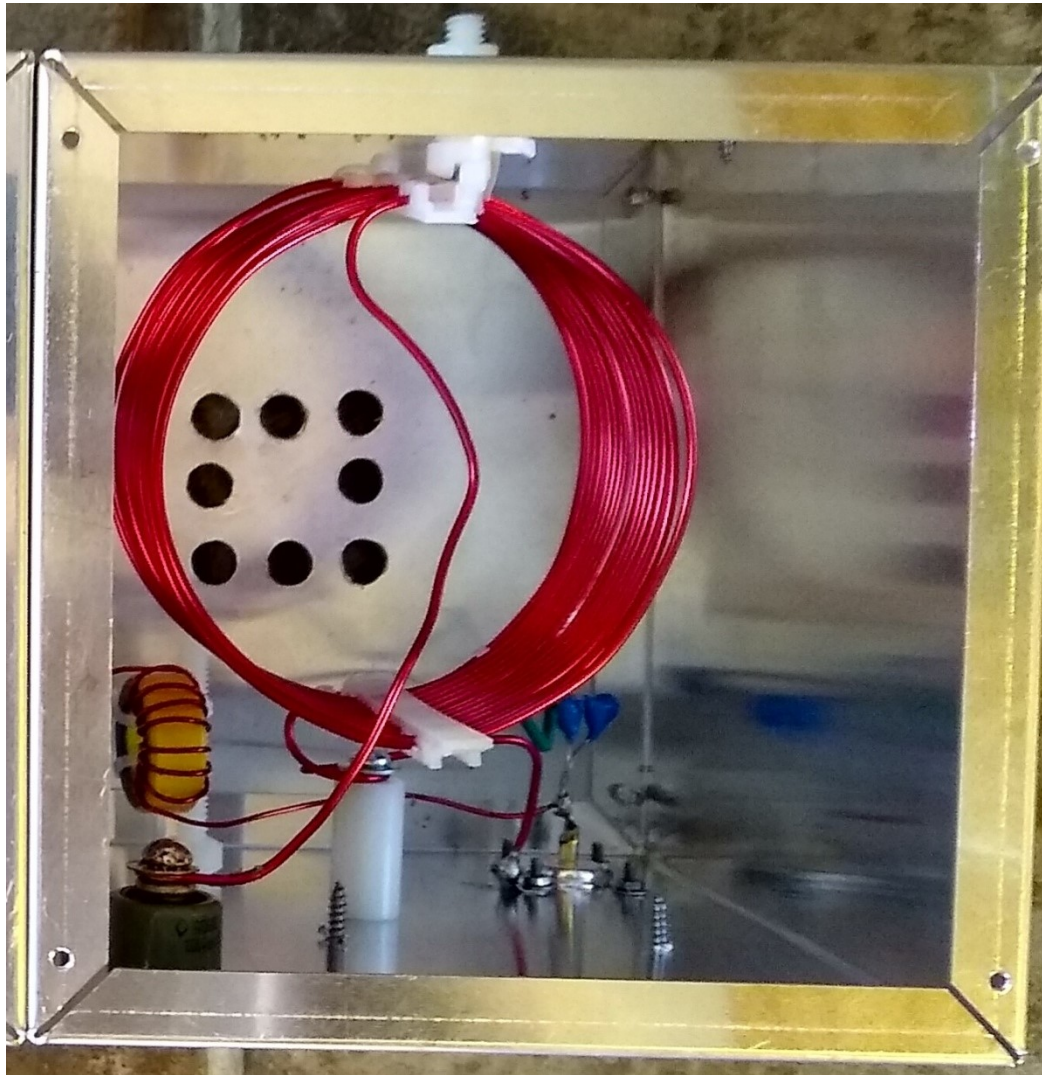

Reprinted with the permission of the ARRL. Copyright ARRL

QUCS Simulation 40 Meters CW USLL Helix Segmental Model (L1, L2 & L3)

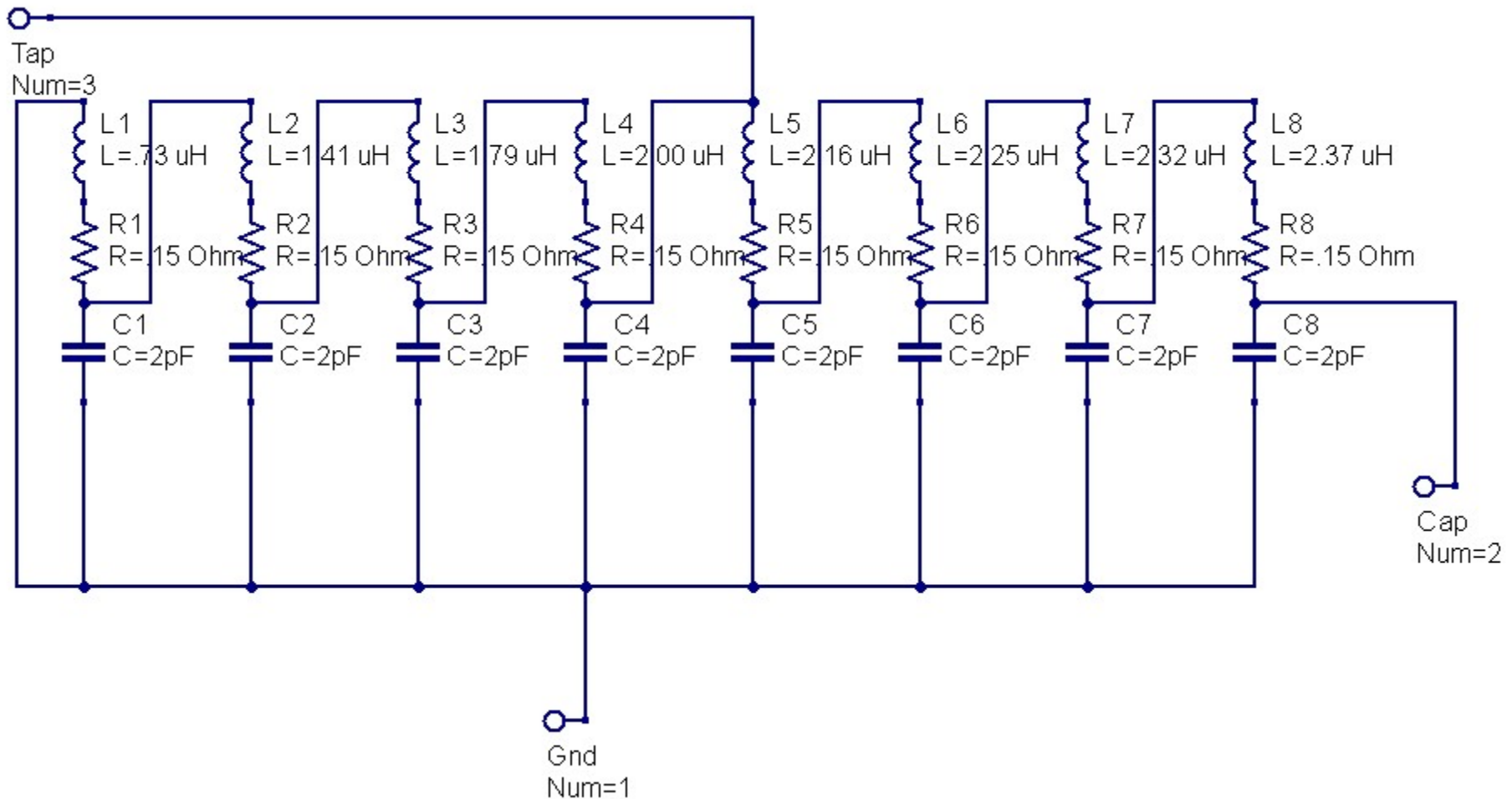

- Each segment is modeled as the incremental inductance to that point as measured to the grounded end, the distributed capacitance to ground and the distributed equivalent RF resistance

QUCS Simulation 40 Meters CW USLL Filter Model

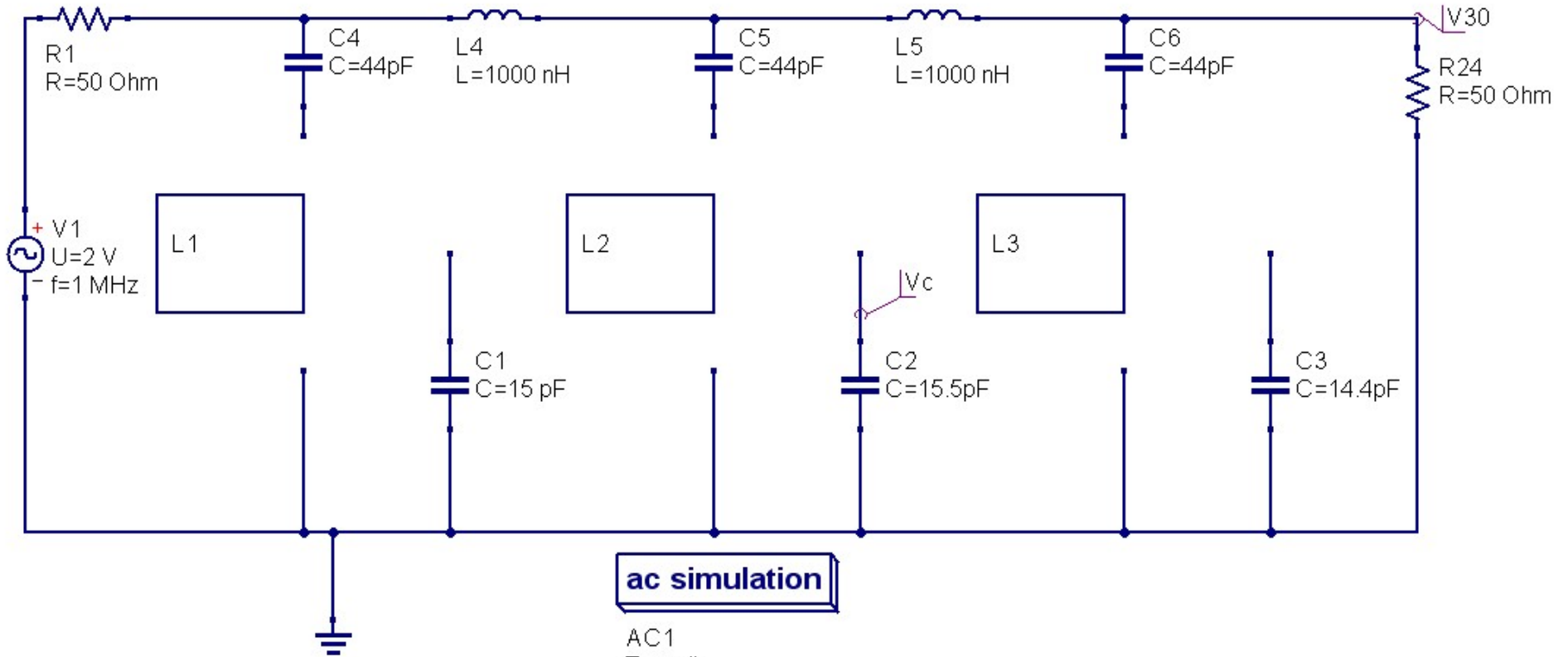

ac simulation

AC1
Type=lin
Start=6.9MHz
Stop=7.5MHz
Points=201

QUCS Simulation 40 Meters CW USLL Results

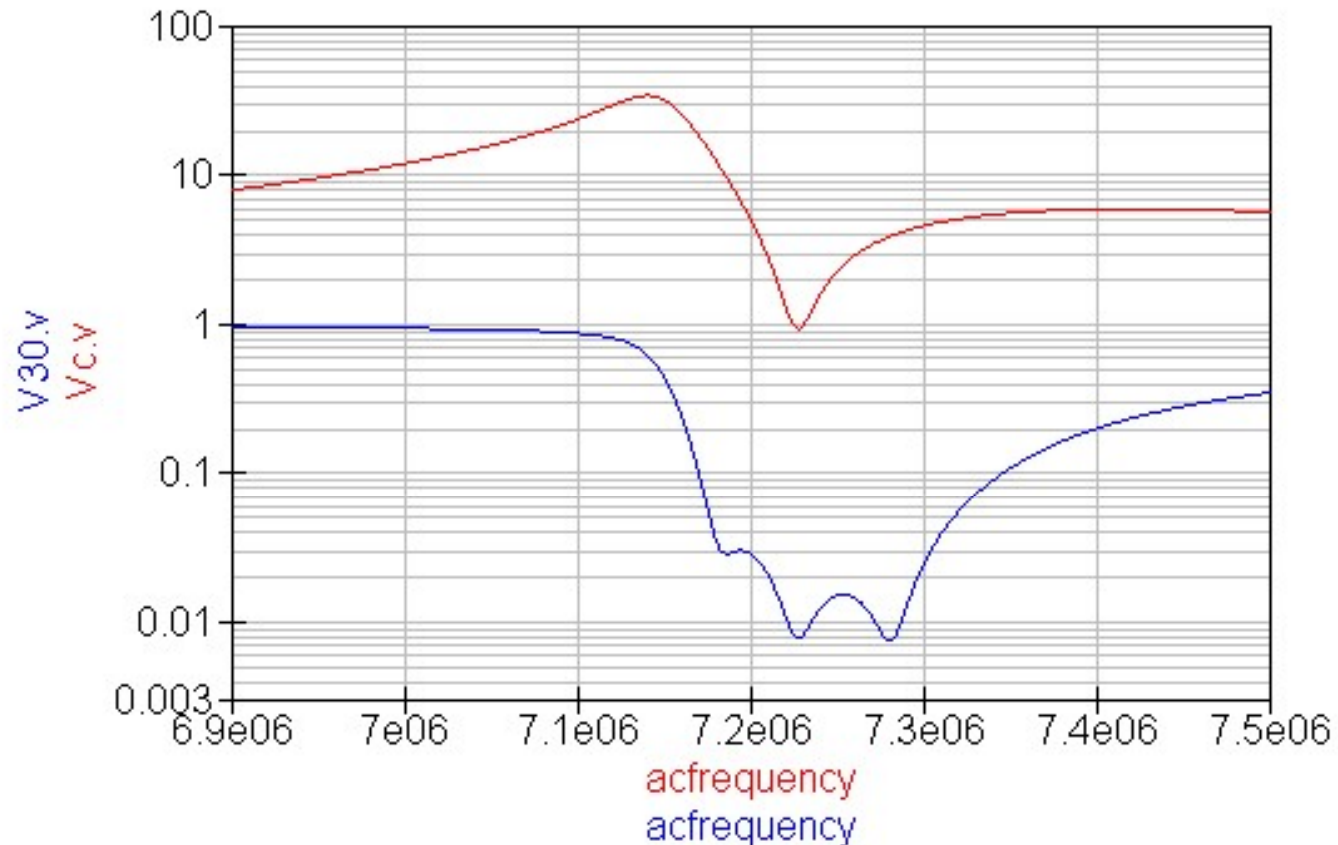

- V30 is the reference at the 50 Ohms output of the filter (about 100 Volts peak for 100 Watts into 50 Ohms)
- Vc is the Voltage on the center resonator capacitor and is about 25x higher or 2500 V at 7.1 MHz (need at least 5 kV caps for margin considering SWR and other issues) (reactance of 15 pF at 14 MHz is about 750 Ohms, so peak current may be about 3.3 Amps or 2.4 Amps RMS)

USLL 20 Meters CW Filter

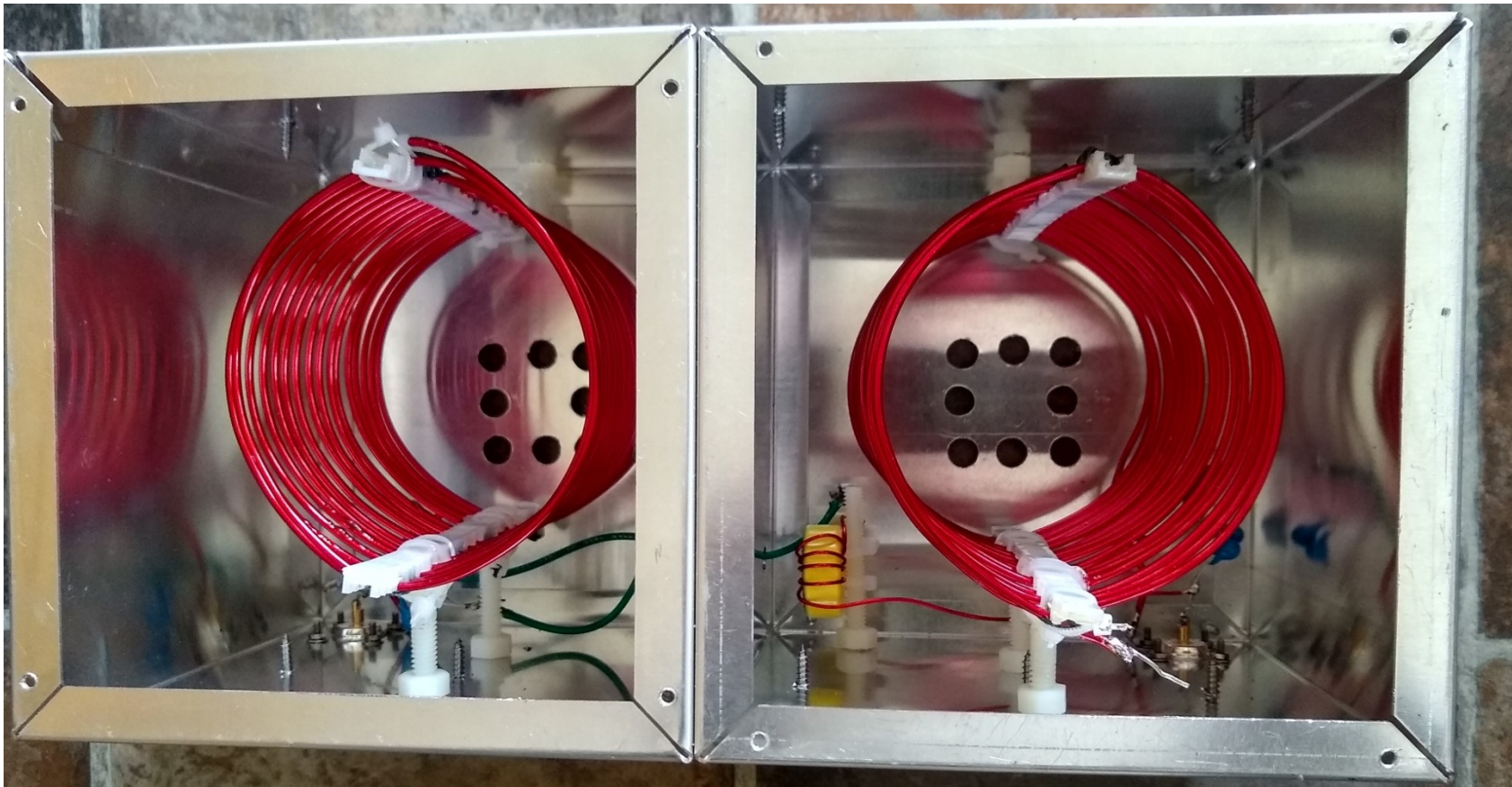

- 2 stage design
- Helical resonators
- ¼" nylon screw mounts

Reprinted with the permission of the ARRL. Copyright ARRL

USLL 80 Meters CW Filter

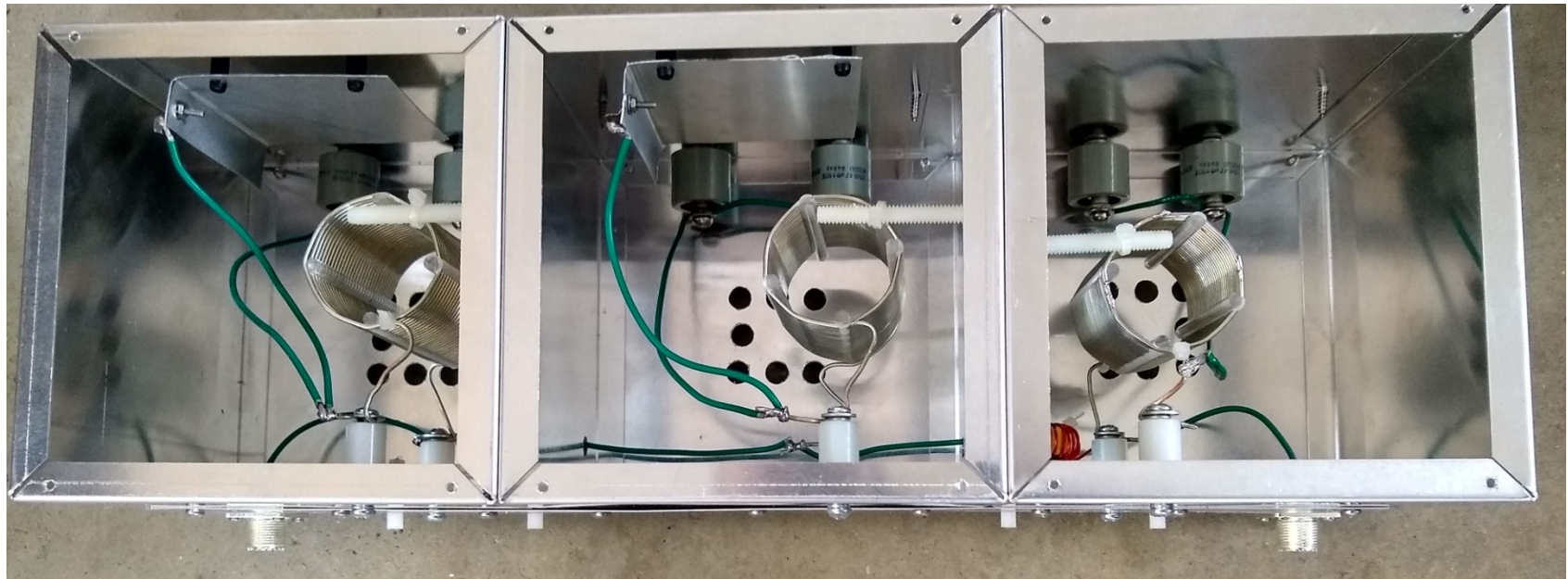

- 2" MFJ coils used for the resonators
- Two doorknob capacitors per chamber on the top wall
- Gimnick air capacitors in chambers 1 and 2 for tuning

Reprinted with the permission of the ARRL. Copyright ARRL

USLL Filter Tuning

- Requires several hours
- Run a NanoVNA in continuous sweep mode
- Place top lid on each chamber (with no screws) to make measurements due to capacitance
- Start with each resonator below desired freq
- Tune center chamber to closest null to transition
- Then tune remaining chambers
- Bandpass resonances are not sensitive
- Trim gimmick air caps for 80 meters
- Trim coil and twist final turn for 40 meters
- Trim coil (slowly as resonance get close) for 20/15 meters

*** The coils in these filters can generate several thousand Volts of RF when excited with 100W TX power – operate at power only with chambers closed ***

20 Meters CW USLL Filter Assembled

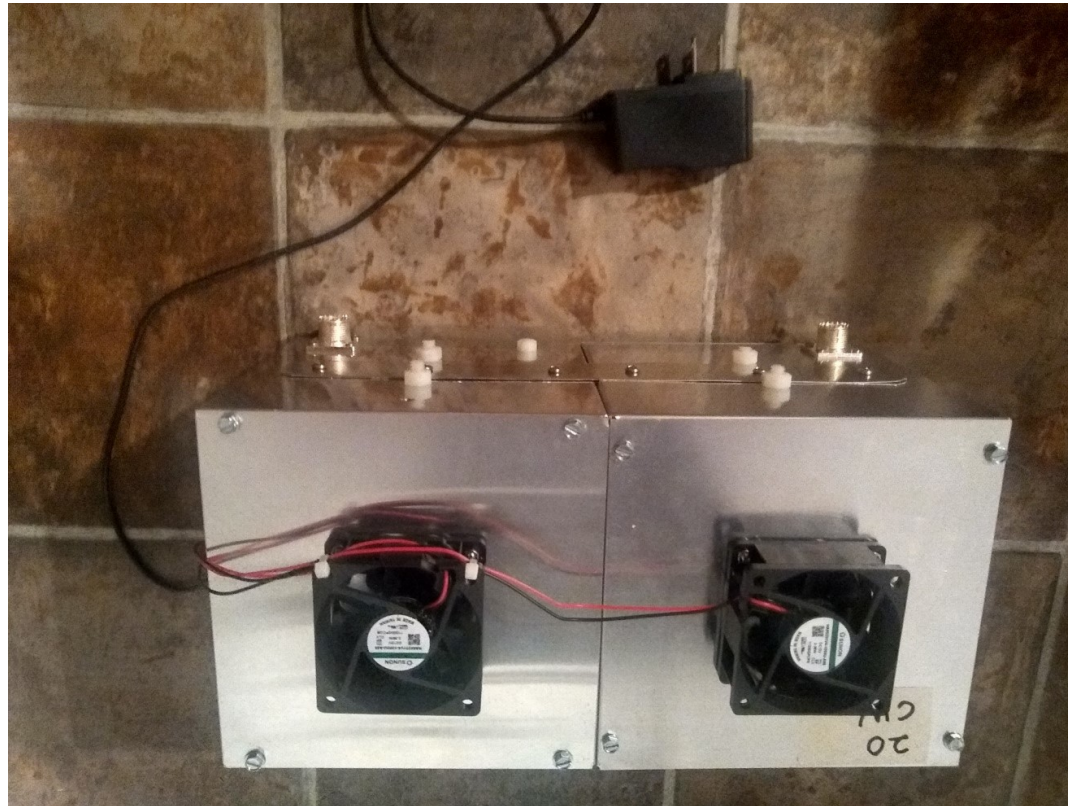

- Small fans cool the chambers to minimize drift in frequency
- 1.5" wide aluminum straps with stainless steel screws connect the chambers and provide a low impedance ground
- Filter sits on rubber feet – allows air flow and protects the chambers

Reprinted with the permission of the ARRL. Copyright ARRL

Making 3.5" Coils



- AD5X, Phil Salas method
 - 3" PVC pipe length 24"
 - Two ½" x 15" slots in the PVC pipe
 - Wooden spacers during construction
 - McMaster nylon strips with 1/8" slots
 - Pipe clamps hold nylon strips and wire
 - Epoxy 2 wires out of 4
-
- 20 Meters coil shown at 4 TPI using #12 enameled copper wire
 - 40 meters coil used 8 TPI using #14 enameled wire

Reprinted with the permission of the ARRL. Copyright ARRL

Winding 3.5" Coils



- Copper wire supply spool mounted on a rod and vise
- Coil form prepared with wooden spacers, McMaster nylon spacers and clamps
- Wind the copper wire in the same direction as the bend on the supply reel to make a smooth coil
- After winding, apply epoxy to one nylon spacer and allow hardening prior to applying epoxy to the other nylon spacer
- Add small tie wraps at the ends of the coil to the nylon spacers for strength

Key Components for USLL Filters

- 6"x6"x6" aluminum boxes for chambers
- MFJ and homebrew large high Q coils
- Doorknob RF capacitors – high voltage/current
- T106-6 toroid cores

References/Resources

- ARRL NCJ Nov/Dec 2021
- <http://www.ka2c.com/field-day-interference/>
- <http://www.ad5x.com/images/Articles/CoilRevB.pdf>
- June 1976 – QST (Pg. 11), Helical-Resonators Design Techniques, Fisk, James R, W1DTY

Conclusions

- High performance Ultra Sharp filters to separate CW and phone on the same band are reasonable to build
- Complexity is modest, but requires care in mechanical construction and filter tuning
- USLL filters suitable for 100W TX/RX are large at 6"x6"x18" but are not heavy and are very usable
- Other techniques are also important – antenna plan – bandpass filters – high performance rigs
- Field Day operation without phone/CW/digital interference is a pleasure

Acknowledgements

Many thanks to these hams and the Antietam Radio Association for support on this work

NI2W Butch Eigenbrode

WA8EIH Steve Struharik

W3PDW Brian Umbrell

WA3PTV Joe Lockbaum

KD3JK Bob Long

K2AVA Herm Niedzielski